



FEATURES

- Up to 1,000,000 duty cycles or 10 year DC life*
- High power and energy
- 1200F to 3,400F capacitance range
- Threaded terminals or laser-weldable posts
- REACH,RoHS Directive Compliant

APPLICATIONS

- High shock and vibration environments
- Automotive subsystems ,Wind turbine pitch control
- Hybrid vehicles ,Rail
- Heavy industrial equipment
- UPS & telecom systems



GENERAL SPECIFICATIONS

Item	Performance
Operating temperature	-40°C to +65°C
Capacitance range	1200F to 3400F
Rated voltage	2.7 V/ 2.85V / 3.0V
Surge voltage	2.85 V/ 3.0V /3.15V
Temperature characteristics	Capacitance change: Within ±20% of initial measured value at +25°C Internal resistance: Within ±200% of initial measured value at +25°C
High temperature load time	After 65°C 1500 hours : Capacitance change: ±20% of initial specified value Internal resistance: Within 1 times of initial specified value
Projected cycle life (From rated voltage to 1/2 rated voltage at 25°C)	After 1,000,000 cycles: Capacitance change: Within ±20 % of initial specified value Internal resistance: Within 2 times of initial specified value
Vibration resistance	Amplitude:1.5mm /Frequency:10~55Hz /Duration: X,Y,Z(2 hrs)/Duration of testing:6 hrs Capacitance change: Within ±20 % of initial rated value Internal resistance: Within 2 times of initial value
Shelf life	After 4 years at 25°C RH≤ 50% without load, the capacitor shall meet the specified endurance limits.

PART NUMBER SYSTEM

CNP	3000	P	270	K12	***
Series	Capacity Code	Cylindrical	Rated voltage(VDC)	Foot Code	Special Code

Casing Display:



DIMENSIONS



CNPXXX PXXX K12

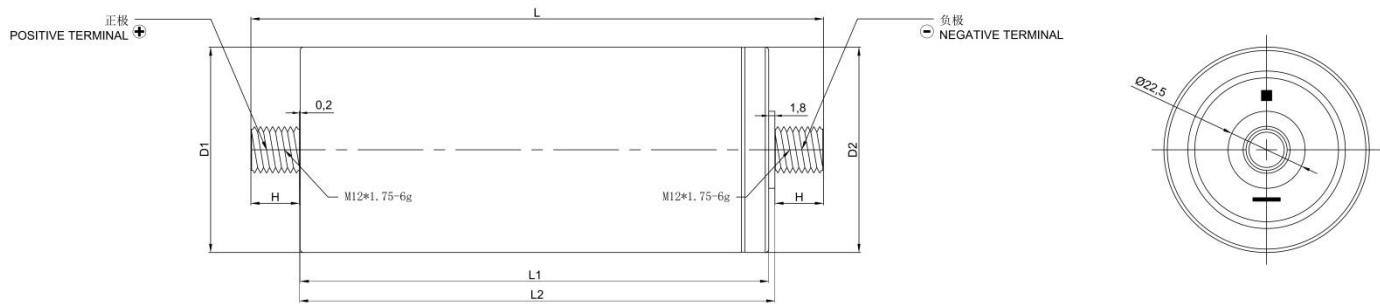

Part Number	Dimensions(mm)						Weight(±5g)
	L(±0.5mm)	L1(±0.5mm)	L2(±0.5mm)	D1(±0.2mm)	D2(±0.5mm)	H(±0.2mm)	
CNP1200P270 K12	113.0	83.0	85.0	60.0	61.0	14.0	320
CNP1500P270 K12	113.0	83.0	85.0	60.0	61.0	14.0	320
CNP2000P270 K12	131.0	102.0	103.0	60.0	61.0	14.0	380
CNP3000P270 K12	166.9	136.9	138.9	60.0	61.0	14.0	520
CNP3400P270 K12	166.9	136.9	138.9	60.0	61.0	14.0	520
CNP3400P285 K12	166.9	136.9	138.9	60.0	61.0	14.0	520
CNP1200P300 K12	113.0	83.0	85.0	60.0	61.0	14.0	320
CNP1500P300 K12	113.0	83.0	85.0	60.0	61.0	14.0	320
CNP2000P300 K12	131.0	102.0	103.0	60.0	61.0	14.0	380
CNP3000P300 K12	166.9	136.9	138.9	60.0	61.0	14.0	520
CNP3400P300 K12	166.9	136.9	138.9	60.0	61.0	14.0	520

CNPXXX PXXX K14

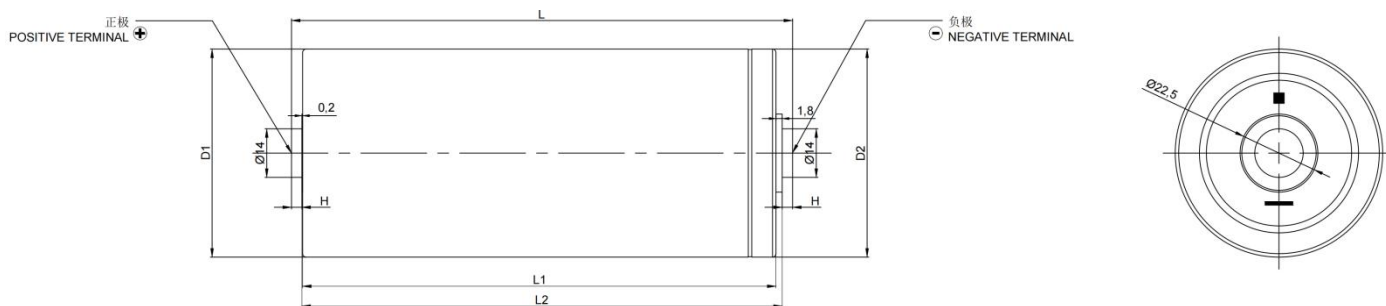

Part Number	Dimensions(mm)						Weight(±5g)
	L(±0.5mm)	L1(±0.5mm)	L2(±0.5mm)	D1(±0.2mm)	D2(±0.5mm)	H(±0.2mm)	
CNP1200P270 K14	91.0	83.0	85.0	60.0	61.0	3.0	310
CNP1500P270 K14	91.0	83.0	85.0	60.0	61.0	3.0	310
CNP2000P270 K14	109.0	101.0	103.0	60.0	61.0	3.0	370
CNP3000P270 K14	144.9	136.9	138.9	60.0	61.0	3.0	510
CNP3400P270 K14	144.9	136.9	138.9	60.0	61.0	3.0	510
CNP3400P285 K14	144.9	136.9	138.9	60.0	61.0	3.0	510
CNP1200P300 K14	91.0	83.0	85.0	60.0	61.0	3.0	310
CNP1500P300 K14	91.0	83.0	85.0	60.0	61.0	3.0	310
CNP2000P300 K14	109.0	101.0	103.0	60.0	61.0	3.0	370
CNP3000P300 K14	144.9	136.9	138.9	60.0	61.0	3.0	510
CNP3400P300 K14	144.9	136.9	138.9	60.0	61.0	3.0	510

STANDARD PRODUCTS



Part Number	Working Voltage (V DC)	Rated Cap. (F)	Capacitance Tolerance	Max.ESR		Maximum Leakage (72hrs/mA)	Rated Current (A)	Max. continuous Current(A)		Peak Current 1s (A)	Power Density (kW/Kg)	Maximum Energy (W.h)	Energy Density (Wh/kg)
				ESRAC (1kHz/mΩ)	ESRDC (mΩ)			ΔT = 15°C	ΔT = 40°C				
2.7V Series													
CNP1200 P270	2.7	1200	-0%to+20%	0.18	0.29	2.8	100	107	175	1411	7.81	1.215	4.34
CNP1500 P270	2.7	1500	-0%to+20%	0.18	0.29	2.8	100	107	175	1411	9.41	1.519	4.80
CNP2000 P270	2.7	2000	-0%to+20%	0.15	0.26	3.0	100	129	210	1775	9.21	2.025	5.33
CNP3000 P270	2.7	3000	-0%to+30%	0.15	0.22	12	100	149	244	2480	8.41	3.038	5.84
CNP3400 P270	2.7	3400	-0%to+30%	0.15	0.22	12	100	149	244	2847	7.50	3.442	6.62
2.85V Series													
CNP3400 P285	2.85	3400	-0%to+30%	0.15	0.22	12	100	153	250	2884	7.37	3.836	7.37
3.0V Series													
CNP1200 P300	3.0	1200	-0%to+20%	0.20	0.31	8	100	103	169	1536	8.57	1.500	5.36
CNP1500 P300	3.0	1500	-0%to+20%	0.20	0.31	8	100	103	169	1536	9.95	1.875	5.90
CNP2000 P300	3.0	2000	-0%to+20%	0.18	0.29	10	100	120	200	1899	9.47	2.500	6.58
CNP3000 P300	3.0	3000	-0%to+30%	0.15	0.22	12	100	146	238	2710	9.03	3.750	7.21
CNP3400 P300	3.0	3400	-0%to+30%	0.13	0.20	12	100	153	250	3035	9.03	4.250	8.17

LIFE TIME AND TEMPERATURE PERFORMANCE

The life of a Super Capacitor is impacted by a combination of operating voltage and the operating temperature according to the following equation :

$$L = L_0 \times 3.25^{\frac{T_0 - T}{10}} \times 1.52^{\frac{V_0 - V}{0.1}}$$

L : is the theoretical lifetime at T temperature;

L₀ : is the working life of the highest rated working temperature;

T : is the actual working temperature;

T₀ : is the highest rated working temperature;

V : is the actual working voltage;

V₀ : is the highest rated working voltage.

*Note : Estimated lifespan: The estimated lifespan under different operating voltages and operating temperatures in a theoretical environment. For the actual service life, please contact us to discuss the working conditions.

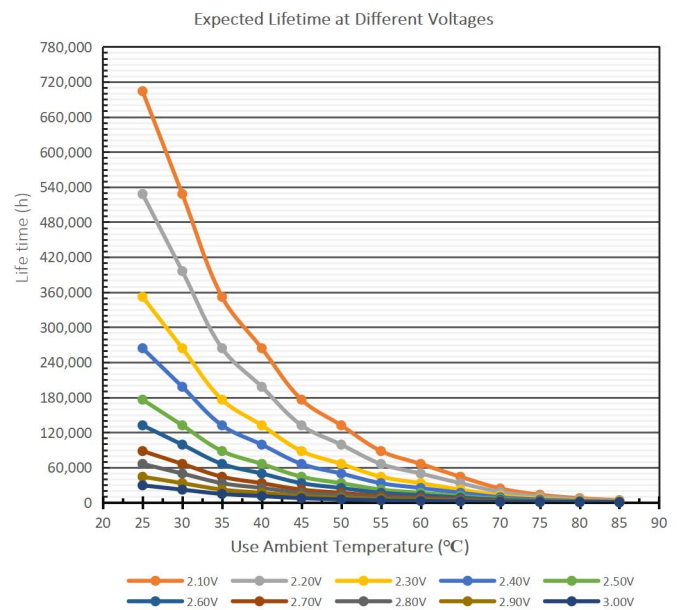

TYPICAL PERFORMANCE

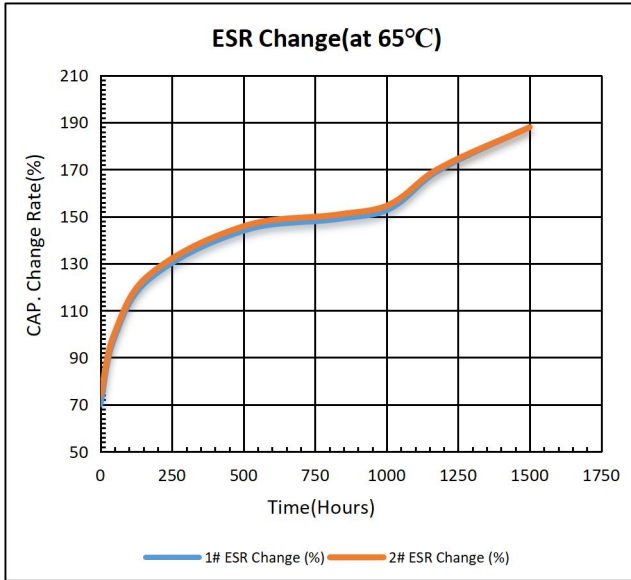

Figure 1: Accelerated Aging ESR Performance
 $V_R = 3.0V, T = 65^\circ C$

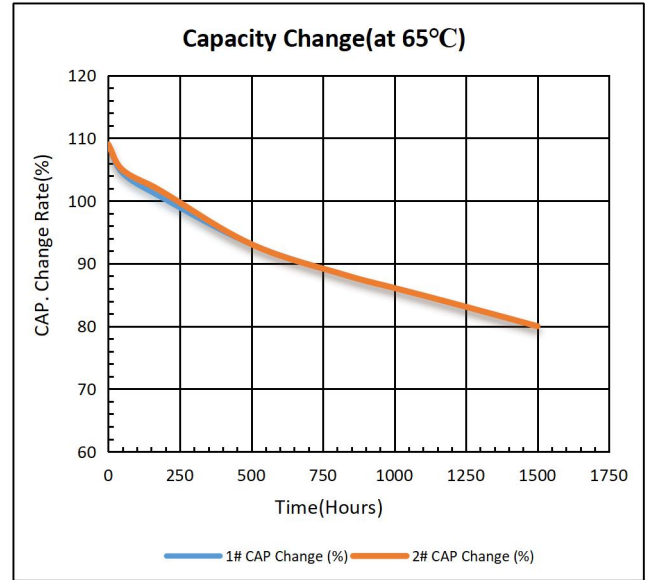

Figure 1: Accelerated Aging Capacitor Performance
 $V_R = 3.0V, T = 65^\circ C$

TEST PROCEDURES

1. Surge Voltage

Absolute maximum voltage, non-repetitive. Duration not to exceed 1 second.

2. Capacitance and ESRDC were measured at 25°C using a test current of 100 A.

3. Maximum Leakage Current

- Current measured after 72 hours at rated voltage and 25°C. Initial leakage current may be higher.
- Module leakage current is the sum of the battery and balancing circuits, if applicable.

4. Maximum peak current

- The current required to discharge the battery/module from rated voltage to half rated voltage in 1 second.

$$I = \frac{1/2 V_R}{\Delta t/C + ESR_{DC}}$$

Where Δt is the discharge time in seconds; in this case $\Delta t = 1$ second.

- The specified maximum peak current should not be used for normal operation and is for reference only.

5. Energy and Power (based on IEC 62391-2)

- Maximum energy storage:

$$E_{max}(Wh) = \frac{1/2 CV_R^2}{3600}$$

- Gravimetric Specific Energy:

$$(Wh/kg) = \frac{E_{max}}{mass}$$

- Usable Specific Power:

$$(W/kg) = \frac{0.12V_R^2}{ESR_{DC} \times mass}$$

- Impedance Match Specific Power:

$$(W/kg) = \frac{0.25V_R^2}{ESR_{DC} \times mass}$$

- Presented Power and Energy values are calculated based on Rated Capacitance & Rated (Max.) ESRDC, Initial values.

6. Cycle Life Test Profile

Cycle life varies depending upon application-specific characteristics. Actual results will vary.

7. Temperature Rise at Constant Current

$$\Delta T = I_{RMS}^2 \times ESR_{DC} \times R_{th}$$

where ΔT : Temperature rise over ambient (°C)

I_{RMS} : Maximum continuous or RMS current (A)

R_{th} : Thermal resistance, cell to ambient (°C/W)

ESR_{DC} : Rated (Max.) ESRDC(Ω).

(Note: Design should consider EOL ESR_{DC} for application temperature rise evaluation.)

8. All CDA supercapacitors have a capacity of less than 10Wh to meet the requirements of Special Regulation 361 according to the United Nations material classification UN3499.

Both individual ultracapacitors and modules composed of these ultracapacitors shipped by CDA can be transported without being considered dangerous goods (hazardous substances) according to the transport regulations.

9. BOL: Beginning of Life, rated initial product performance

EOL: End of Life criteria.

- Capacitance: 80% of min. BOL rating
- ESRDC: 2x max. BOL rating

* To ensure the safe use of CNP series products, please click this link: [White Paper on the User Manual of this Product](#)